



31.08.25

# IXINA CLASSIC GROTE PRIJS STAD HALLE

Heren elites - UCI 1.2

Start Edingensesteenweg: 12:30 u  
Aankomst voorzien rond de klok van 17 uur



## Bestuur VZW Halle Cycling



Voorzitter : DE SMET JOHAN

Secretaris : VANDERCAMMEN FREDDY

Penningmeesters : JACOBS JOHAN , WOUTERS DENNIS

Leden :  
BERCKMANS JEAN PIERRE  
BELLEMANS JACKY  
BERGHMANS DAVID  
BORREMANS FABIO  
BORREMANS PASCAL  
CRABBE JACKY  
DESCHOUWER JURGEN  
DENEYER BRUNO  
HANSENS FRANCIS

HELLEBAUT ROLAND  
PAESMANS JOHAN  
PEUTEMAN BOB  
ROESEMS BERT  
TORDEURS RONNY  
VAN HAELEN MARC  
WAMPERS JEAN MARIE







TITLE PARTNER



TOP PARTNERS



**PHENIX GROUP**  
CONSTRUCTION & DEVELOPMENT

 <b>BOUW</b>	 <b>BOREN &amp; ZAGEN</b>	 <b>RAMEN &amp; DEUREN</b>
 <b>AFBRAAK</b>	 <b>INFRA</b>	



In samenwerking met de Stad halle , Koninklijke Wielervedclub Buizingen Sportief  
Gemeente Beersel en politiezone Zennevallei en Federale Politie



## Organisatie comité

### IXINA CLASSIC – Grote prijs Stad Halle 2025



Wedstrijdcoördinator	De Smet Johan	0478 27 24 88
Adjunct wedstrijdcoördinator	Van Haelen Marc	0497 11 29 93
Koersdirecteur	Wampers Jean - Marie	0475 75 35 45
Regulator	Peuteman Bob	0470 55 84 22
Veiligheidscoördinator	Tubbe Lorenzo	0479 61 14 52
Veiligheid Safety	Conings Rudi	0485 76 74 40
Regulator Start	Berckmans Jean - Pierre	0474 05 17 20
	Deneyer Bruno	0475 76 14 90
	Tordeurs Ronny	0477 27 34 68
	Hanssens Francis	0475 23 48 55
Verantwoordelijke Vip & Fanzone	Jacobs Johan	0475 23 18 84
	Paesmans Johan	0475 53 73 53
	Deneyer Bruno	0475 76 14 90
	Crabbe Jacky	0478 55 07 41
	Wouters Dennis	0498 17 23 70
Chauffeur VIP	Roesems Bert	0475 87 17 40
Verantwoordelijke seingever	Borremans Fabio	0470 57 07 04
	Hellebaut Roland	0476 21 79 01
	Borremans Pascal	0474 42 43 25
Verantwoordelijke uitdeling lunchpakketten	Bellemans Jacky	0475 42 95 11
Verantwoordelijke opname GPM	Hanssens Francis	0475 23 48 55



## College van commissarissen:

---

<b>Voorzitter / Président UCI</b>	<b>SEVRUK Valerii</b>
<b>Commissaris 2</b>	KLINCKAERT Yves
<b>Commissaris 3</b>	REMUE Stefaan
<b>Commissaris 4</b>	VAN PRAET Niels
<b>Aankomstrechtter</b>	STREULENS Pascal
<b>Commissaris moto 1</b>	NEERINCKX Timmy
<b>Commissaris moto 2</b>	OTTOEY Steve
<b>Piloot moto Bel cycling 1</b>	DEURBROECK Olaf
<b>Piloot moto Bel cycling 2</b>	GEEROMS Theo
<b>Wedstrijdadministratie</b>	WILLEMS Mia
<b>Operator Transponders</b>	WILLEMS Mia
<b>Fotofinish</b>	DEVROE Steven
<b>Technisch afgevaardigde</b>	LISSENS Eddy
<b>Telecom team jury 1</b>	LISSENS Eddy
<b>Commissaris Radio – Tour</b>	BOLLEN Marc
<b>Moto info 1</b>	VAN IMPE Vincent
<b>Ardoisier</b>	REMUE Alain

**RADIOTOUR : 164.63125 Mhz – Kan 1**





# Definitief parcours IXINA CLASSIC - Grote prijs Stad Halle 2025

Door Ronny TORDEURS

BEKIJK OP MOBIEL



↔ Lengte: 25.8 km

📍 Edingensesteenweg, 1500 Halle, België

⬆ Stijging: 298 m

📍 Edingensesteenweg, 1500 Halle, België

📊 Moeilijkheidsgraad: 6/10

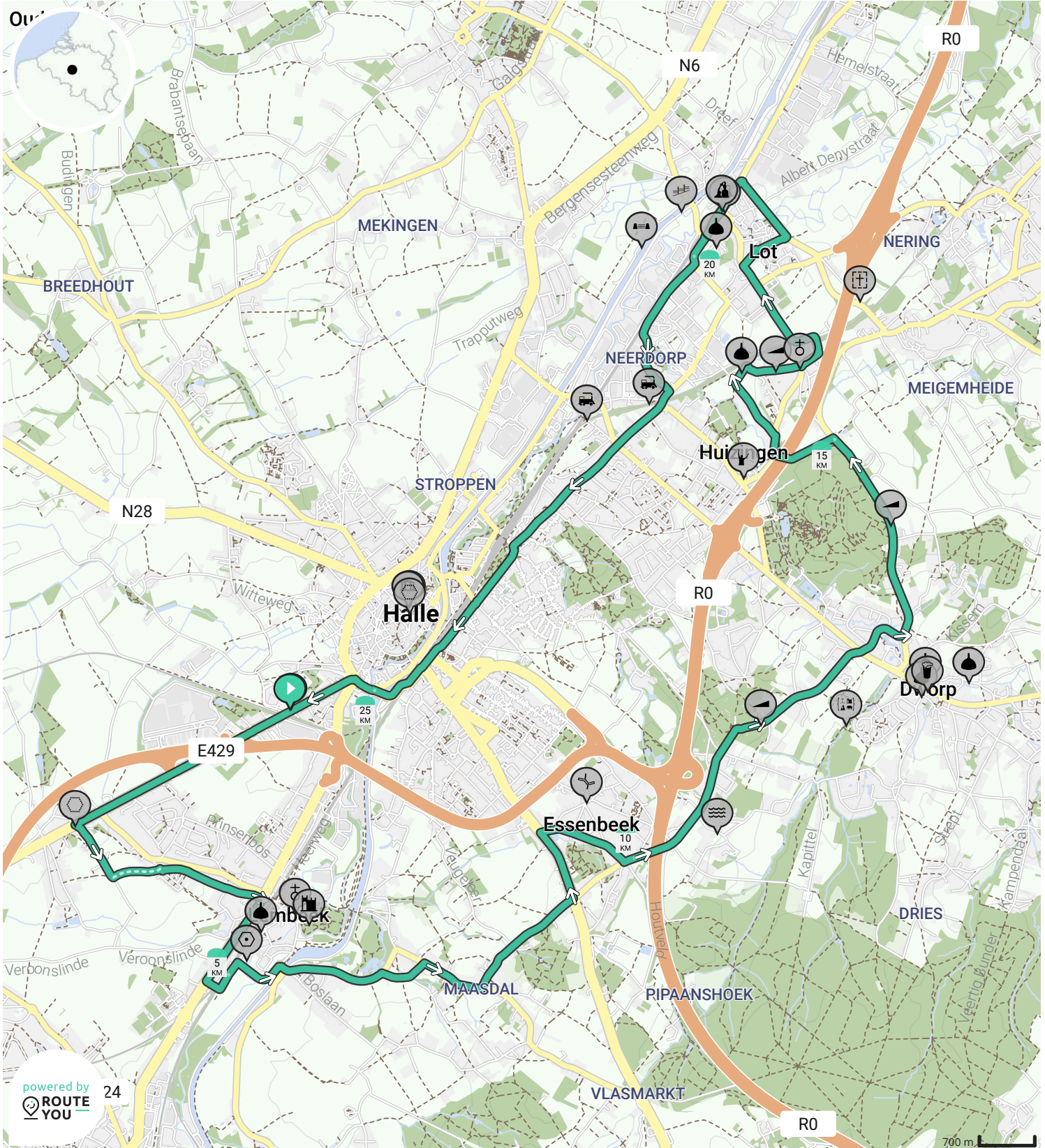
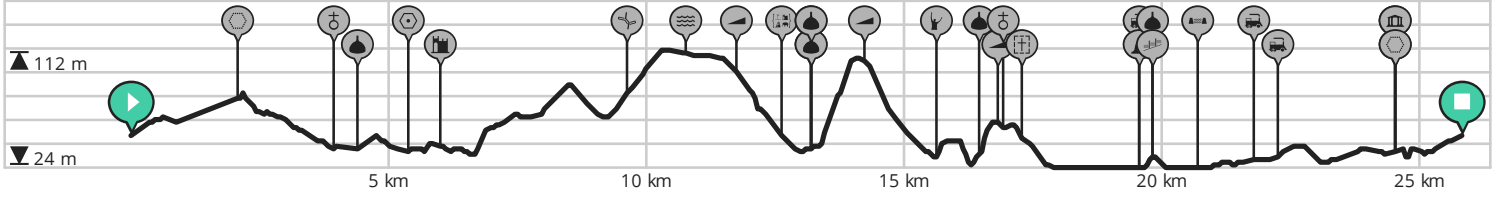

powered by ROUTE YOU

24

HALLE	Officieuze start om 12: 30 u
	Edingensesteenweg
LEMBEEK	Kruiskensheide
	Sterrestraat
	Bergensesteenweg
	Officiële start
LEMBEEK	Bergensesteenweg - Steengroefstraat
	Zuiderstraat
	Perregatstraat
	Heldenstraat
	Dokter Spitaelslaan
	Dokter Spitaelslaan
	Dokter Spitaelslaan
HALLE	Maasdal
	Nijvelsesteenweg
	Kasteelstraat
	Arenbergstraat
DWORP	Krabos
	Gravenhoflaan
	Lotsesteenweg
	Bruineput
	Lotsesteenweg
BEERSEL	Batenborg
	Watermolenstraat
	Sollenberg
	Kesterbeeklaan
LOT	Lakenberg
	Dworpsestraat
	Pastoriestraat
	Beerselsestraat
	Zennestraat
	Jozef Huysmanslaan
	Stationsstraat
	Breedveld
	Gustaaf Demeurslaan
HUIZINGEN	Guido Gezellestraat
	Beerselsestraat
BUIZINGEN	Octaaf de Kerchove Exaerdestraat
HALLE	Vandenpeereboomstraat
	Vogelpers
	Rene Deboecklaan
	Bergensesteenweg
	Edingensesteenweg
	Edingensesteenweg
LEMBEEK	kruiskensheide
	Passage 1
	Passage 2
	Passage 3
	Passage 4
	Passage 5
	Passage 6
	Aankomst / Finish

KM		45/u	42/u	40/u	
12:30					
	↑				
	←				
	←				
	→				
- 4 km		12:35:20	12:35:42	12:36:00	
0	Km	↑	45/u	42/u	40/u
0	Km	↑	12:35:20	12:35:42	12:36:00
439	M	←	12:35:55	12:36:19	12:36:39
842	M	→	12:36:27	12:36:54	12:37:15
1,28	Km	→	12:37:02	12:37:31	12:37:55
1,35	Km	↖	12:37:08	12:37:37	12:38:01
2,18	Km	→	12:37:47	12:38:17	12:38:44
2,59	Km	→	12:38:17	12:38:54	12:39:27
3,22	Km	←	12:39:37	12:40:18	12:40:49
4,31	Km	←	12:41:04	12:41:51	12:42:27
4,94	Km	→	12:41:55	12:42:45	12:43:24
5,71	Km	←	12:42:56	12:43:51	12:44:33
6,15	Km	↑	12:43:32	12:44:29	12:45:13
8,53	Km	↑	12:46:42	12:47:53	12:48:47
9	Km	←	12:47:20	12:48:33	12:49:30
		GPM			
10,8	Km	←	12:49:44	12:51:07	12:52:12
11,5	Km	↖	12:50:40	12:52:07	12:53:15
12,1	Km	→	12:51:28	12:52:59	12:54:09
12,7	Km	↖	12:52:16	12:53:50	12:55:03
12,9	Km	←	12:52:32	12:54:07	12:55:21
13,5	Km	↑	12:53:20	12:54:59	12:56:15
14	Km	→	12:54:00	12:55:42	12:57:00
14,2	Km	↑	12:54:16	12:55:59	12:57:18
14,5	Km	←	12:54:40	12:56:24	12:57:45
15,1	Km	←	12:55:28	12:57:16	12:58:39
15,4	Km	↑	12:55:52	12:57:42	12:59:06
15,7	Km	↑	12:56:16	12:58:07	12:59:33
15,9	Km	→	12:56:32	12:58:27	12:59:51
17,2	Km	→	12:58:16	13:00:16	13:01:48
17,7	Km	↑	12:58:56	13:00:59	13:02:33
17,8	Km	↑	12:59:04	13:01:17	13:02:45
19,1	Km	↑	13:00:48	13:03:09	13:04:39
20,3	Km	↑	13:02:24	13:04:42	13:06:27
20,9	Km	↑	13:03:12	13:05:33	13:07:21
21,1	Km	↖	13:03:28	13:05:50	13:07:39
21,5	Km		13:04:08	13:43:33	13:08:24
47,3	Km		13:38:40	14:20:33	13:47:15
73,1	Km		14:13:12	14:57:33	14:26:06
98,9	Km		14:47:44	15:34:33	15:04:57
124,7	Km		15:22:16	16:11:33	15:43:48
150,5	Km		15:56:48	16:11:33	16:22:39
176,3	Km		16:31:20	16:48:33	17:01:30

way out & way in via Warande

way out & way in via Lotsesteenweg

way out & way in via Dworpsestraat

way out & way in via Bergensesteenweg



**Way Out 3 : Pastoriestraat – Dworpsestraat**

**Way In 3 : Molenstraat – G. Demeurslaan**

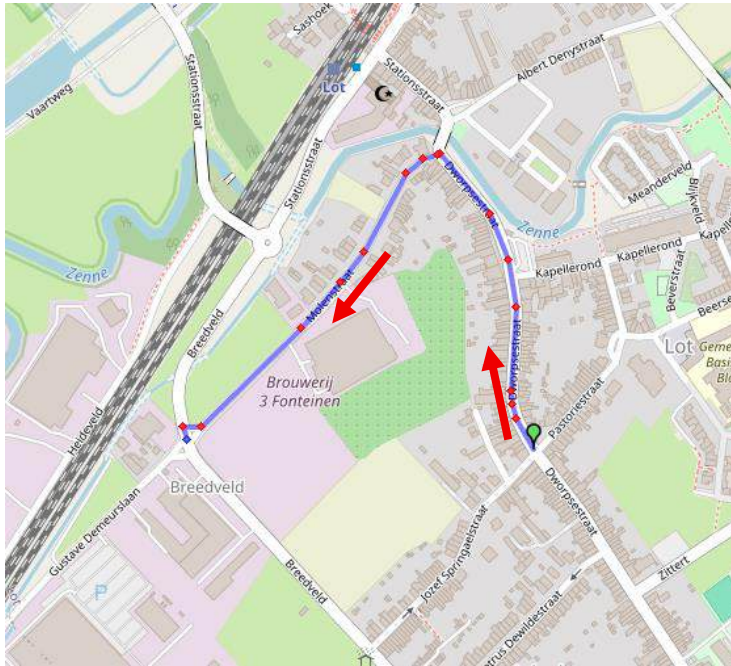

**Grondgebied Beersel**

**Lot centrum**

**Way Out 4 : Bergensesteenweg – Bergensesteenweg**

**Way In 4 : Bergensesteenweg – Bergensesteenweg**

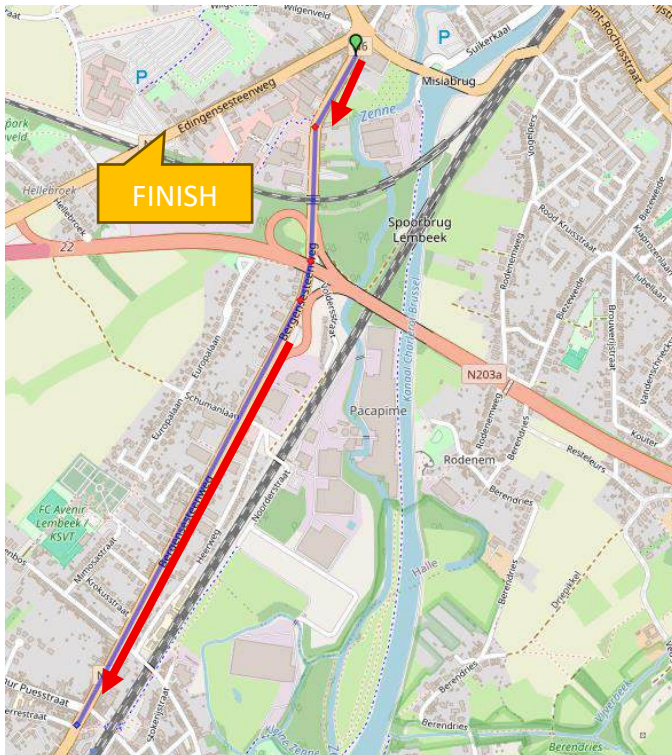

**Grondgebied Halle**

# PPO 1



## Komende van Brussel E19:

Afslag 21 Halle - N203a afslag Halle Centrum  
Bergensesteenweg - August Demaeghtlaan  
Beertsestraat - Viktor Demesmaekerstraat  
Parking Colruyt Group  
(volg pijlen TEAMS)



## En venant de Bruxelles E19:

Sortie 21 Halle - sortie N203a Halle Centrum  
Bergensesteenweg - August Demaeghtlaan  
Beertsestraat - Viktor Demesmaekerstraat  
Parking Colruyt Group (suivre fêches TEAMS)

## Coming E19 from Brussels:

Exit 21 Halle - N203a exit Halle Centrum  
Bergensesteenweg - August Demaeghtlaan  
Beertsestraat - Viktor Demesmaekerstraat  
Parking Colruyt Group (follow arrows TEAMS)



Opgepast afrit 22 afgesloten van 7u tot en met 19u  
Attention, la sortie 22 est fermée de 7h jusqu'à 19h  
Please note that exit 22 is closed from 7AM until 7PM



## PPO 2



### Komende uit Doornik E429 :

Kruispunt lichten links Rodenemweg - Vogelpers  
Rene Deboecklaan - August Demaeghtlaan Beertsestraat  
Viktor Demesmaekerstraat  
Parking Colruyt Group (volg pijlen TEAMS)

### En venant de Tournai E429 :

Carrefour à gauche Rodenemweg - Vogelpers  
Rene Deboecklaan - August Demaeghtlaan  
Beertsestraat - Viktor Demesmaekerstraat  
Parking Colruyt Group (suivre flèches TEAMS)

### Coming from Tournai E429:

Crossroads lights on the left Rodenemweg - Vogelpers  
Rene Deboecklaan - August Demaeghtlaan Beertsestraat  
Viktor Demesmaekerstraat  
Parking Colruyt Group (follow arrows TEAMS)



Opgepast afit 22 afgesloten van 7u tot en met 19u  
Attention, la sortie 22 est fermée de 7h jusqu'à 19h  
Please note that exit 22 is closed from 7AM until 7PM



## WEDSTRIJDINFO – INFO DE L'ÉPREUVE – RACE INFO

**Permanentie – Permanence – Race Headquarters:**  
**Vanaf 8:00 u**

**Zondag | Dimanche | Sunday**  
**31/08/2025**

Aankomst – Arrivée – Arrival : Colruyt Group  
Edingsesteenweg 196 , 1500 Halle (Tel : 02/ 363 55 45)

**Inschrijving – Inscription – Inscriptions:**

**Zondag | Dimanche | Sunday**  
**31/08/2025**

**8:00 h – – – – 10 h**

Aankomst – Arrivée – Arrival : Colruyt Group  
Edingsesteenweg 196 , 1500 Halle (Tel : 02/ 363 55 45)

**Briefing ploegleider – Réunion Equipes – Team manager**  
**meeting: 10 :15 h**

**Zondag | Dimanche | Sunday**  
**31/08/2025**

Aankomst – Arrivée – Arrival : Colruyt Group  
Edingsesteenweg 196 , 1500 Halle (Tel : 02/ 363 55 45)

**Briefing chauffeurs en mobiele seingevers:**

**Zondag | Dimanche | Sunday**  
**31/08/2025**

**11:15 h**

Aankomst – Arrivée – Arrival : Colruyt Group  
Edingsesteenweg 196 , 1500 Halle (Tel : 02/ 363 55 45)

**Perszaal – Salle de presse – Press room:**

**Zondag | Dimanche | Sunday**  
**31/08/2025**

Aankomst – Arrivée – Arrival : Colruyt Group  
Edingsesteenweg 196 , 1500 Halle (Tel : 02/ 363 55 45)

Tekenen renners – Signatures coureurs – Signs Cyclists : Parking Colruyt Group , Edingsesteenweg 196 , 1500 Halle

**Speaker: Stefaan De Decker**



# WEDSTRIJDINFO – INFO DE L'ÉPREUVE – RACE INFO

## Anti doping – contrôle antidopage

Zondag | Dimanche | Sunday  
31/08/2025

Aankomst – Arrivée – Arrival : Colruyt Group  
Edingsesteenweg 196 , 1500 Halle (Tel : 02/ 363 55 45)

## Evacuatie hospitalen – Hopitaux – Hospitals :

**Algemeen ziekenhuis Sint Maria Halle**      Ziekenhuislaan 100 , 1500 Halle  
Tel: 02 363 12 11  
Urg: 02 363 05 10

**Hopital Universitaire Erasme U.L.B.**      Lenniksebaan 808 , 1070 Anderlecht  
Tel : 02 555 31 11  
Urg :02 555 34 05

**Universitair Ziekenhuis Jette**      Laarbeeklaan 101 , 1090 Jette  
Tel : 02 477 41 11

**Brandweer Halle**      Vanhamstraat 1 , 1501 Halle  
**Brandweer Lennik**      Tel : 02 451 49 11  
Tel : 02 532 42 98

## INFO :

### Start / Départ om 12:30 u

Colruyt Group – Edingsesteenweg 196 , 1500 Halle (Tel : 02/ 363 55 45)

Opstellen sportdirecteurs :      **Viktor Demesmaekerstraat** , 1500 Halle

Opstellen jurywagens :      Parking Colruyt group Edingsesteenweg 196 , 1500 Halle

Deelnemers per ploeg :      Minimum 5 en maximum 7

Wegwerpzone :      Edingsesteenweg, 1500 Halle

Foto finish :      Rechts

Bevoorradingzone :      Edingsesteenweg , 1500 Halle

Afleiding ploegleiders :      600 m voor de aankomst rechtdoor naar August Demaeghtlaan  
en dan via Beertsestraat en Viktor Demesmaekerstraat  
naar achterzijde parking Colruyt

Radio Freq :      164.63125 Mhz – Kan 1

Verplichte route PPO :      Volg PPO start en aankomst / Suivez PPO / Follow PPO Finish



# WEDSTRIJDINFO - INFO DE L'ÉPREUVE - RACE INFO

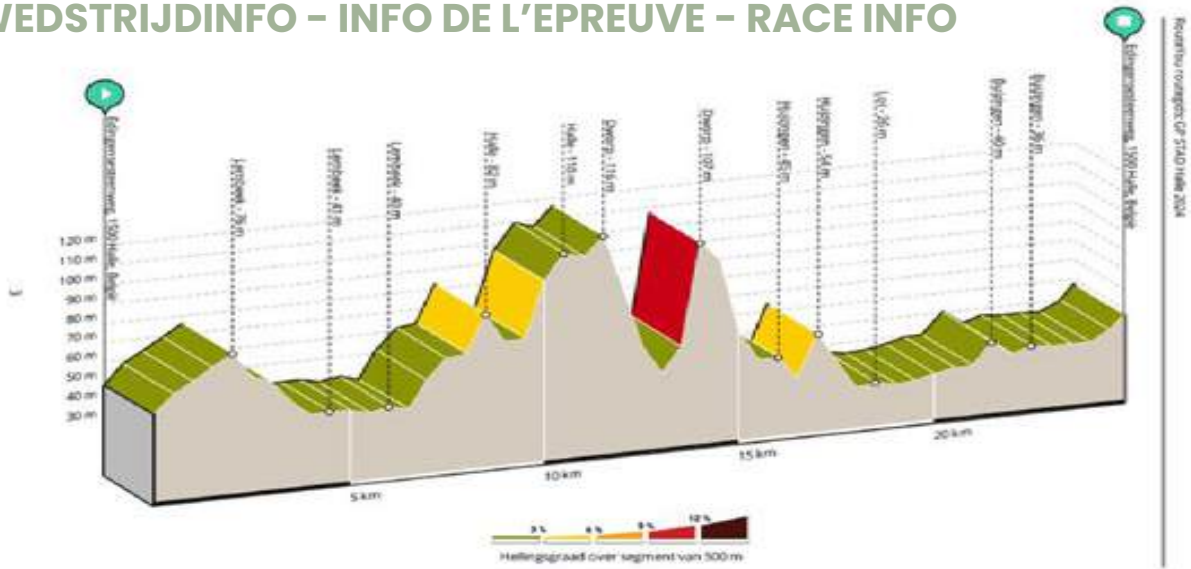

## Bruineput

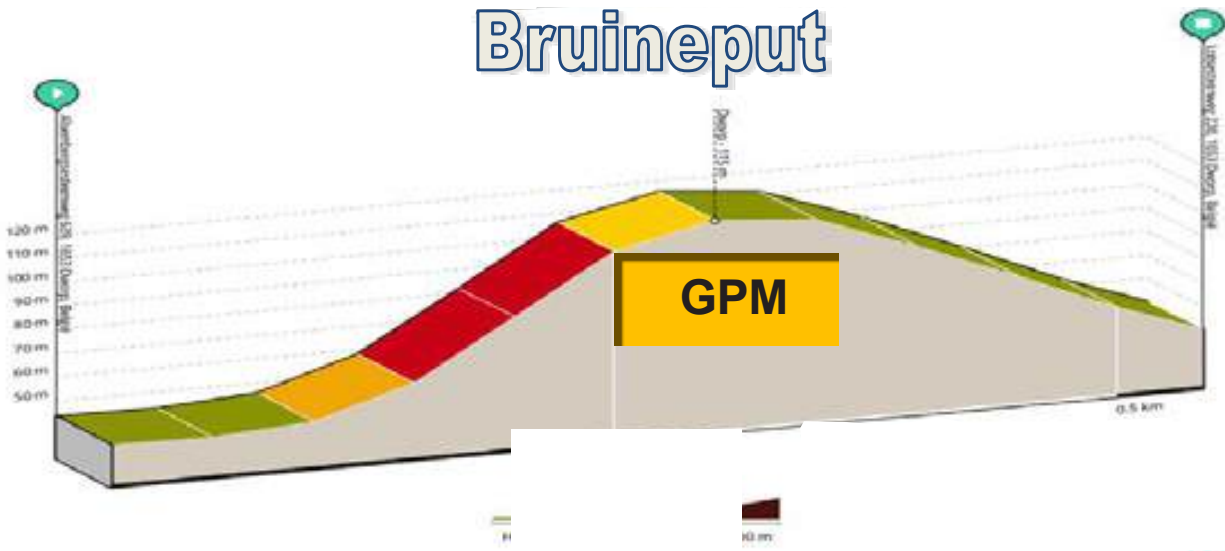

## Sollenberg

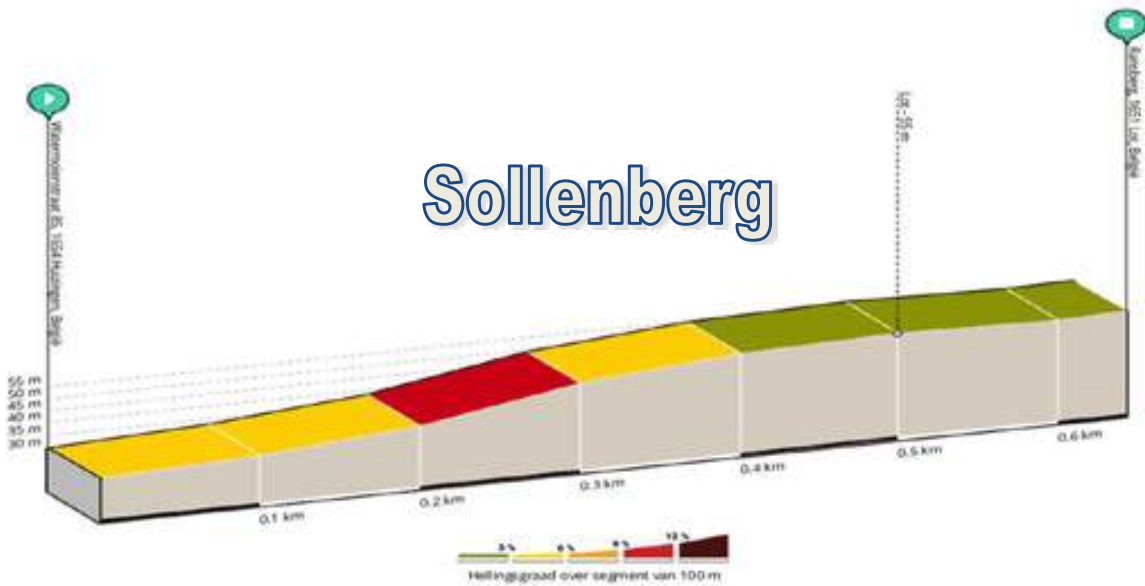

# BEVOORRADING – RAVITAILLEMENT – FEED ZONE

**1m vanaf het fietspad en in 5 boxen per team /  
A 1m de la piste cyclable et dans 5 box par équipes /  
1m from the cycle path and n 5 boxes per team**

\*\*\*\*\* Ploegwagens keren terug via Prinsenbos,  
Bergensesteenweg richting Halle (afleiding vanaf rond punt  
Bevrijdingsplein , Beertsestraat , Viktor Demesmaeckerstraat,  
parking Colruyt Group )

\*\*\*\*\* Retour des voitures des équipes via la Prinsenbos , Bergensesteenweg en direction de Halle  
(déviation du rond- point Bevrijdingsplein , Beertsestraat, Viktor Demesmaeckerstraat, parking Colruyt  
Group)

\*\*\*\*\* Team cars return via Prinsenbos , Bergensesteenweg  
towards Halle (diversion from Bevrijdingsplein roundabout,  
Beertsestraat, Viktor Demesmaeckerstraat, Colruyt Group car park)

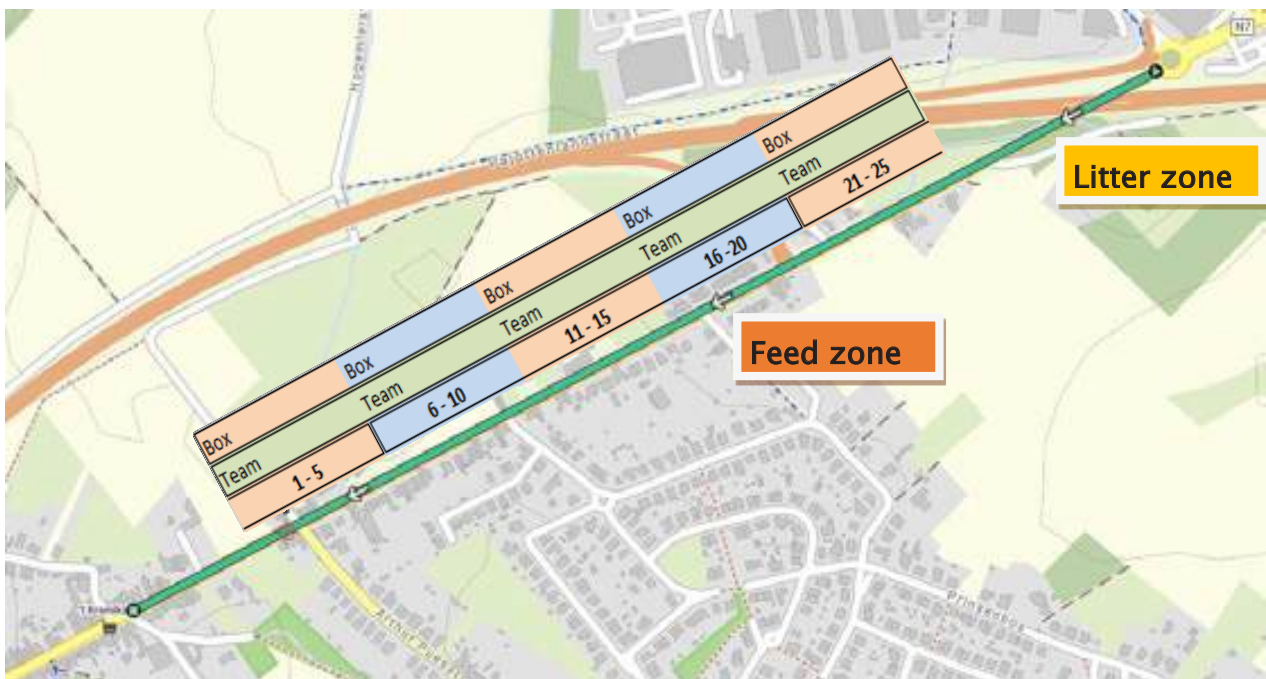

	1	2	3	4	5	6	7	8	9
NL	Parking Teams	Parking Belgian Cycling & Moto's, Politie	Parking publiek & VIP	Finish	Opstelling renners	Opstelling wedstrijd caravaan	Opstelling voor wedstrijd	Permanente	
FR	Parking Equipes	Parking Belgian Cycling & Moto's, Police	Parking Public & VIP	Finish	Composition coureurs	Composition des caravanes	Composition de la compétition	Permanence	
ENG	Parking Teams	Parking Belgian Cycling & Moto's, Police	Public & VIP parking	Finish	Rider line - up	Caravan competition line - up	Line - up Competition	Permanence	

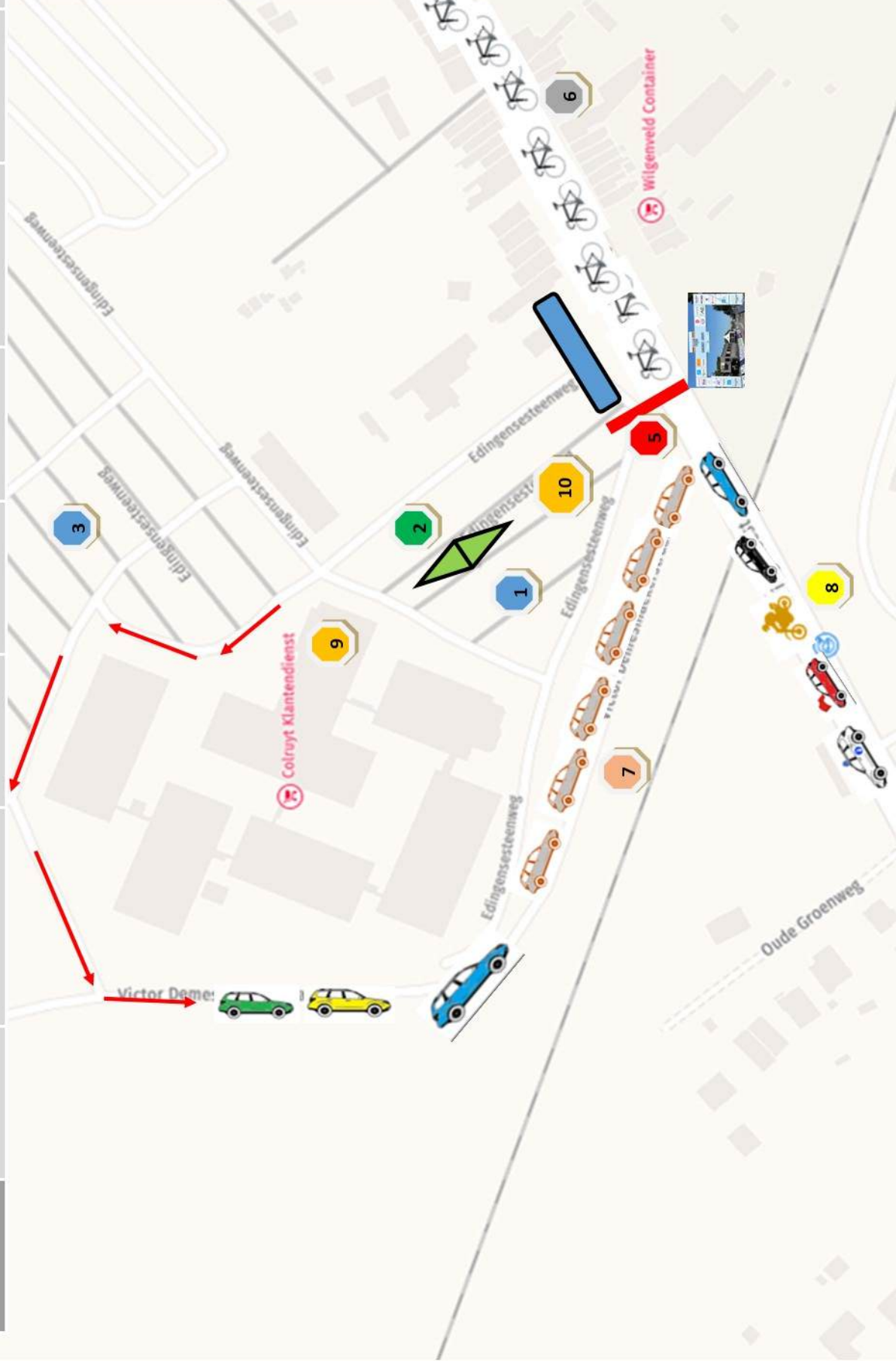
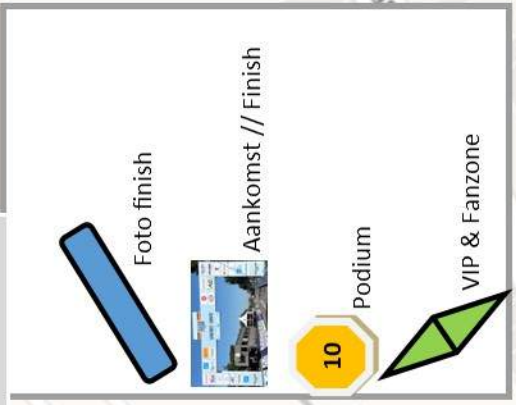

# PARKINGS



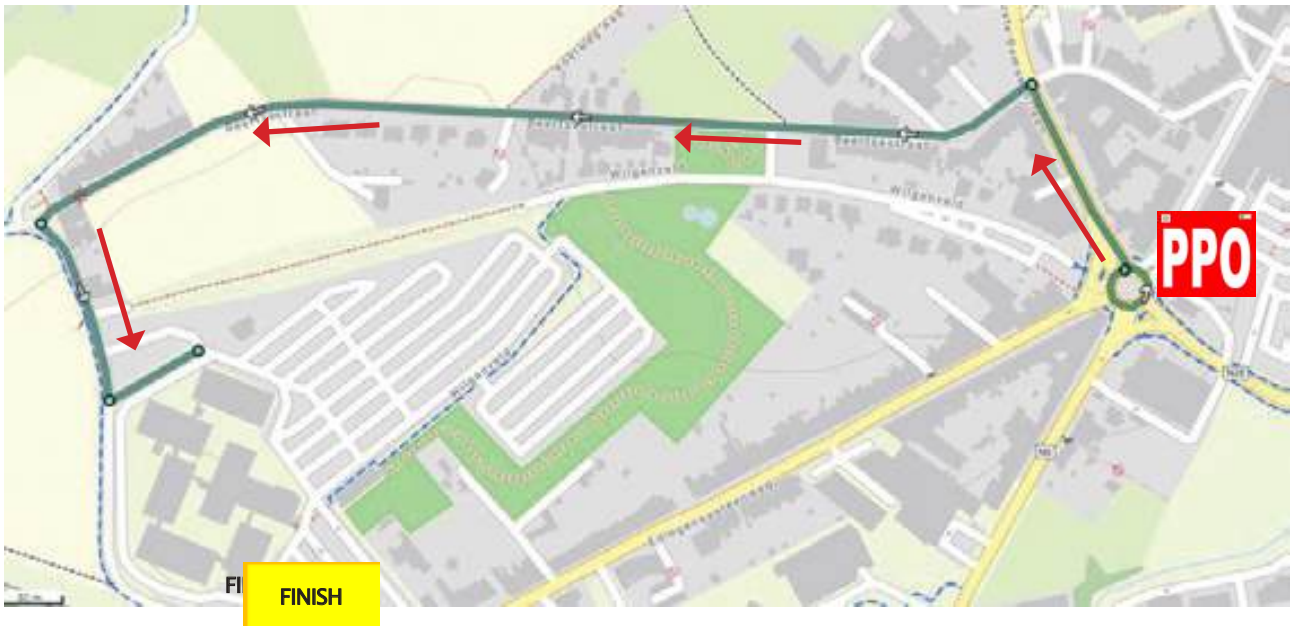

**AFLEIDING VOLGWAGENS - DEVIATION DES VÉHICULES -  
DISTRACTION VEHICLES**

August Demaeghtlaan - Beertsestraat - Viktor Demesmaekerstraat - Parking Colruyt group

**Samenwerking veiligheid Boplan**



1 KM

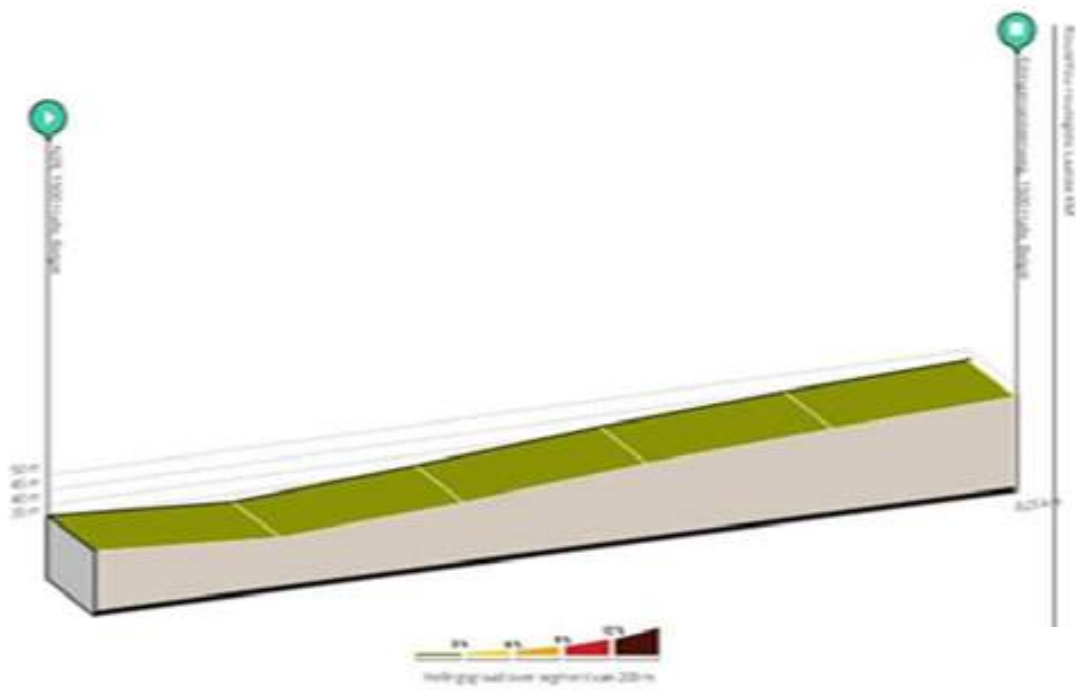
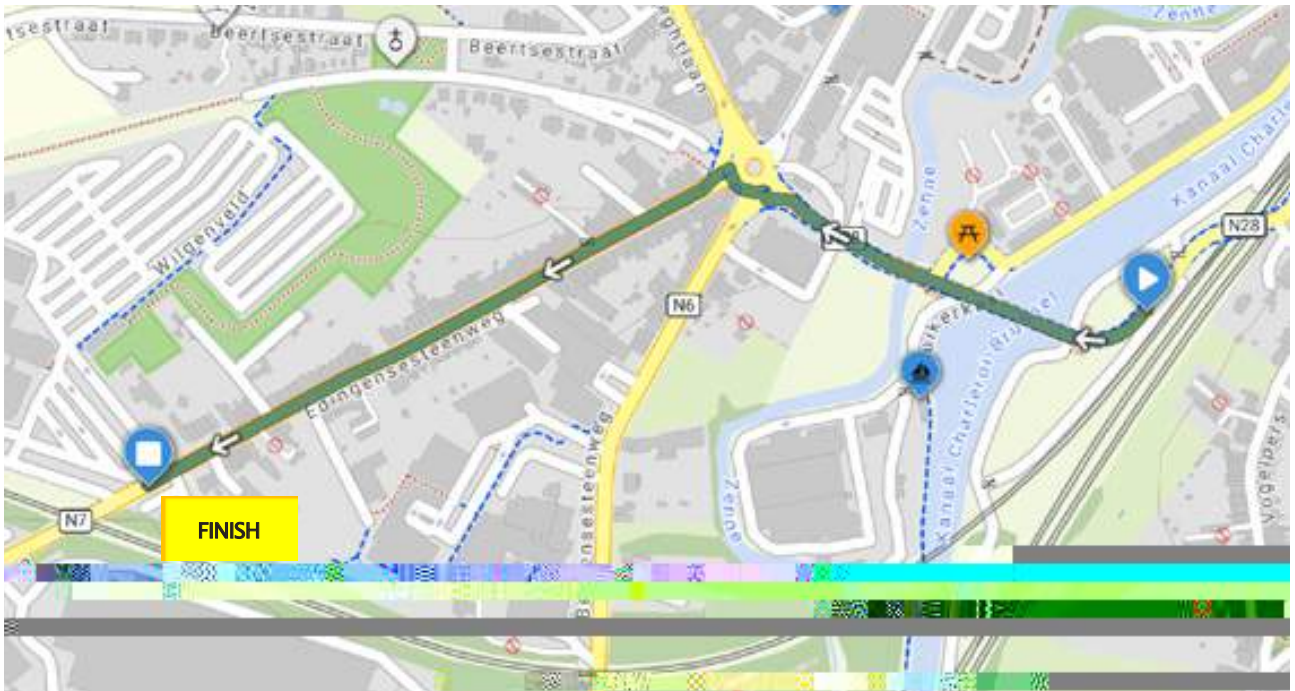

2 KM

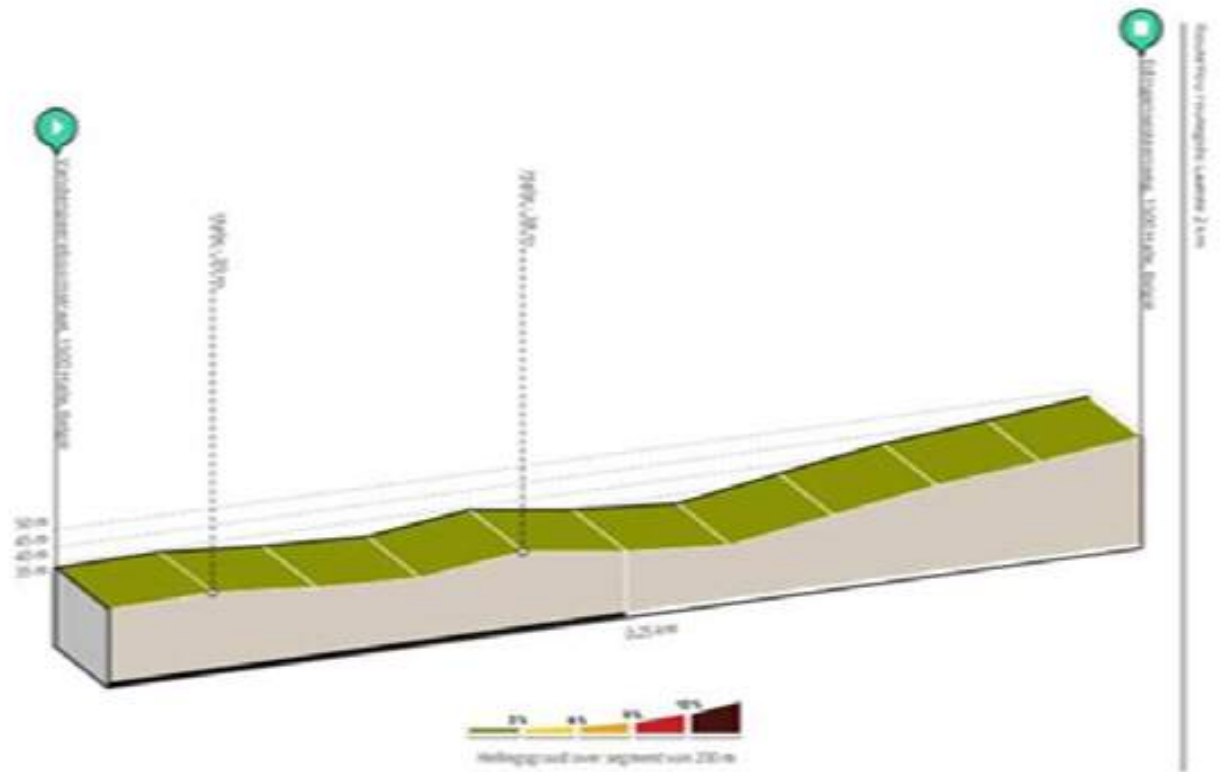

# 3 KM

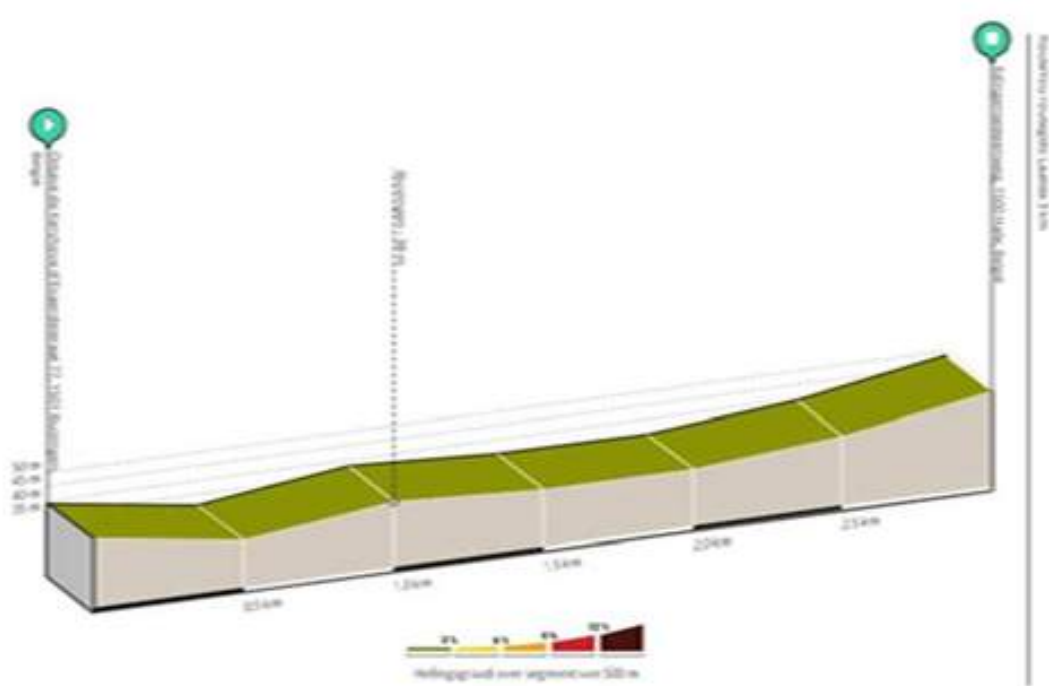
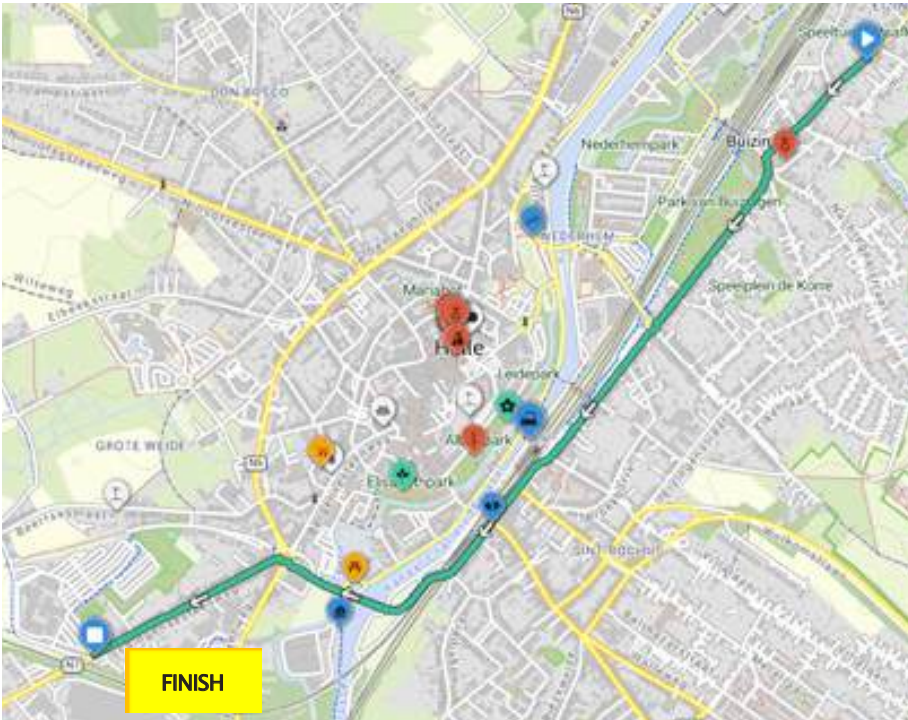

# WEDSTRIJDREGLEMENT GROTE PRIJS STAD HALLE ME 1.2

## 31 AUGUSTUS 2025

ART.1. Organisatie. "De Grote Prijs Stad Halle - IXINA CLASSIC - " wordt georganiseerd door Halle Cycling vzw (Jozef Debusscherstraat 49, 1500 Halle - België). Deze internationale koers wordt gereden op zondag 31 Augustus 2025 volgens de reglementen van de UCI en Belgian Cycling (KBWB).

ART.2. Type wedstrijd & deelname. De Grote Prijs Stad Halle is een wedstrijd ME1.2 UCI voor elites en beloften uit volgende teams: • Belgische UCI ProTeams • Buitenlandse UCI ProTeams (max. 2) • UCI continentale teams • UCI professionele cyclo cross teams • Nationale teams • Regionale en club teams • Het minimum aantal renners per ploeg is vastgelegd op 5, maximum 7.

ART.3. Permanentie. De permanentie bij de start is in de gebouwen van de Colruyt Groep, Edingensesteenweg 196 - 1500 Halle - +32 474 78 98 28, op zondag 31 Augustus 2025 van 8.00u tot 18.00u De bevestiging van de deelnemers die aan de start komen en het afhalen van de rugnummers door de verantwoordelijke van de ploeg gebeurt op de permanentie tussen 8.00u en 10.00u. De vergadering met de ploegleiders, in aanwezigheid van het college van commissarissen, heeft in hetzelfde gebouw plaats om 10.15u, conform Art.1.2.087 van het UCI-reglement. De permanentie aan de aankomst vindt plaats op zondag 31 augustus 2025, in de gebouwen van de Colruyt group, Edingensesteenweg 196, 1500 Halle

ART.4. Radio Tour. De wedstrijd informatie wordt uitgezonden op kanaal 1 164.63125 Mhz - van "Radio-Tour".

ART.5. Neutrale technische assistentie. De neutrale technische assistentie wordt verzekerd door MERIDA. Deze dienst is verzorgd door 2 neutrale voertuigen, en 1 neutrale moto

ART.6. Veiligheid. De deelnemers en de toegestane volgers zijn verplicht alle aanwijzingen van de koersdirectie, officials en federale politie onmiddellijk op te volgen.

ART.7. Startprocedure. Alle renners wordt gevraagd om deel te nemen aan de ploegenvoorstelling op het podium aan de officiële start. De presentatie zal plaatsvinden op de parking van Colruyt groep tussen 11.00u en 12.15u. Dubbele rugnummers en teamoutfit zijn verplicht. Iedere renner is verplicht zich aan de officiële startlijn op te stellen en vandaar de start te nemen.

ART.8. Tijdslimiet. Elke renner, die buiten de tijdslimiet van 8% achterstand op de tijd van de winnaar aankomt, zal niet mee geklasseerd worden. De tijdslimiet kan door het College van Commissarissen, in samenspraak met de organisator, verhoogd

worden in geval van uitzonderlijke omstandigheden.

ART.9. Rangschikkingen - Bonificaties. De volgende rangschikking zal opgemaakt worden: de individuele eindrangschikking volgens de volgorde van het overschrijden van de aankomstlijn op het einde van de laatste lokale ronde. De rangschikking bepaalt de toekenning van de prijzen. Er zijn geen andere rangschikkingen of bonificaties.

ART.10. Klassementsprijzen. Het prijzenpakket bedraagt in totaal € 6.050 en is als volgt bepaald:  
1) € 2.425 2) € 1.210 3) € 610 4) € 305 5) € 240 6) € 180 7) € 180 8) € 120 9) € 120 10) € 60 11) € 60 12) € 60 13) € 60 14) € 60 15) € 60 16) € 60 17) € 60 18) € 60 19) € 60 20) € 60

ART.11. : Bijkomende prijzen geschonken door IXINA :  
1ste : waardebon 5.000 € / 2de waardebon 3.000 € / 3de waardebon 2.000 €

GPM : BRUINEPUT : 1ste : 500€, 2de : 300€, 3de : 200 €  
Passage : 2,3,4,5,6 / Punten **1ste** : 5p , **2de** : 3p , **3de** : 1p

Om in aanmerking te komen moet de renner de volledige wedstrijd uitrijden

ART.12. Medische controle - Antidopingcontrole. Het antidopingreglement van de UCI is volledig van toepassing op deze wedstrijd. Bovendien past zich de Belgische antidopingwetgeving toe, in overeenstemming met de wetsvoorschriften van België en volgens de antidopingwetgeving van het Vlaamse Gewest. De antidopingcontrole vindt plaats in de gebouwen Colruyt, Edingensesteenweg 196, 1500 Halle

ART.13. Protocol. Volgens artikel 1.2.112 van de UCI reglement dienen volgende renners zich voor het protocol aan te bieden: de eerste drie geklasseerde renners van de wedstrijd. Ze zullen zich aanbieden in een maximale termijn van 10 minuten na hun aankomst, alsook winnaar van de GPM

ART.14. Straffen. Het straffenbarema van de UCI is het enige dat van toepassing is.

ART.15. Wegwijzers. Langsheen de omloop worden op zichtbare plaatsen richtingsborden geplaatst, waarvan een specimen wordt uitgehangen in het inschrijvingslokaal. De organisatoren kunnen op geen enkele manier aansprakelijk worden gesteld voor wegvergissingen door renners en of volgers.

ART.16. UCI puntenbarema. 1) 40p 2) 30p 3) 25p 4) 20p 5) 15p 6) 10p 7) 5p 8) 3p 9) 3p 10) 3p

ART. 17. Kleedkamers zijn voorzien in sportcomplex De Bres, Monseigneur Senciestraat 13, 1500 Halle // Tel : 02/365 98 40



# RÈGLEMENT DU CONCOURS GRAND PRIX STAD HALLE ME 1.2

## 31 AOÛT 2025

ART.1. Organisation. "De Grote Prijs Stad Halle - IXINA CLASSIC -" est organisé par l'asbl Halle Cycling (Jozef Debusscherstraat 49 , 1500 Halle - Belgique). Cette course internationale sera disputée le dimanche 31 Août 2025 selon les règlements de l'UCI et du cyclisme belge (KBWB).

ART.2. Type d'épreuve et participation. Le Grote prijs Stad Halle est une compétition ME1.2 UCI pour les élites et les promesses des équipes suivantes: - UCI Pro-Teams belges - UCI ProTeams étrangers (max. 2) - Equipes continentales UCI - Equipes professionnelles cyclo cross UCI - Equipes nationales - Equipes régionales - Le nombre minimum de coureurs par équipe est fixé à 5, maximum 7.

ART.3. Permanence. La permanence au départ se tiendra dans les locaux de Colruyt Group, Edingensesteenweg 196 - 1500 Halle - +32 474 78 98 28, le dimanche 31 Août 2025 de 8h00 à 18h00. La confirmation des participants arrivant au départ et le retrait des dossards par le chef d'équipe auront lieu à la permanence entre 8h00 et 10h00. La réunion avec les chefs d'équipe, en présence du Collège des Commissaires, aura lieu à 10h15 conformément à l'Art. 1.2.2.2. La réunion avec les chefs d'équipe, en présence du Collège des Commissaires, a lieu dans le même bâtiment à 10h15, conformément à l'Art. 1.2.087 du règlement de l'UCI. La permanence à l'arrivée aura lieu le dimanche 31 Août 2025, dans les bâtiments de Colruyt Group, Edingensesteenweg 196 - 1500 Halle.

ART.4. Radio Tour. Les informations relatives à la compétition seront diffusées sur le canal 1 de "Radio Tour" sur 164.63125 MHz.

ART.5. Assistance technique neutre. L'assistance technique neutre est assurée par MERIDA. Ce service est assuré par 2 véhicules neutres et 1 moto.

ART.6. Sécurité. Les participants et les accompagnateurs autorisés sont tenus de suivre immédiatement toutes les instructions de la direction du parcours, des officiels et de la police fédérale.

ART.7. Procédure de départ. Tous les coureurs sont priés de participer à la présentation de l'équipe sur le podium lors du départ non officiel. La présentation aura lieu sur le parking du Colruyt Group entre 11h00 et 12h15. Le double dossard et la tenue d'équipe sont obligatoires. Chaque coureur est tenu de s'aligner sur la ligne de départ officielle et de prendre le départ à partir de celle-ci.

ART.8. Temps limite. Tout coureur qui arrive en dehors du temps limite de 8% par rapport au temps du vainqueur ne sera pas classé. Le temps limite peut être augmenté par le collège des commissaires,

en concertation avec l'organisateur, en cas de circonstances exceptionnelles.

ART.9. Classement - Bonifications. Le classement suivant sera établi : le classement final individuel selon l'ordre de passage de la ligne d'arrivée à la fin du dernier tour local. Le classement détermine l'attribution des prix. Il n'y a pas d'autres classements ou bonifications.

ART.10. Prix du classement. Les prix s'élèvent au total à 6 050 € et sont déterminés comme suit : 1) €2.425 2) €1.210 3) € 610 4) € 305 5) € 240 6) € 180 7) € 180 8) € 120 9) € 120 10) € 60 11) € 60 12) € 60 13) € 60 14) € 60 15) € 60 16) € 60 17) € 60 18) € 60 19) € 60 20) € 60

ARTICLE 11. : Lots supplémentaires offerts par IXINA : 1er : bon de 5.000,00 € / 2ème bon de 3.000,00 € / 3ème bon de 2.000,00 €  
GPM BRUINEPUT: 1 ste : 500€ / 2 de : 300€ / 3 de : 200 €  
Passage : 2,3,4,5,6 /// Points 1 ste : 5p / 2 de : 3p / 3 de : 1p  
Pour se qualifier, le coureur doit terminer la course dans son intégralité.

ART.12. Contrôle médical - Contrôle antidopage. Le règlement antidopage de l'UCI s'applique intégralement à cette épreuve. En outre, la législation antidopage belge s'applique, conformément aux dispositions légales de la Belgique et à la législation antidopage de la Région flamande. Le contrôle antidopage aura lieu dans le bâtiment Colruyt, Edingensesteenweg 196, 1500 Halle.

ART.13. Protocole. Suivant l'article 1.2.112 du règlement de l'UCI, doivent se présenter au protocole : les trois premiers coureurs classés de l'épreuve. Ils se présenteront dans un délai maximum de 10 minutes après leur arrivée, ainsi que le gagnant du GPM.

ART.14. Pénalités. Le barème des pénalités de l'UCI est le seul applicable.

ART.15. Panneaux de signalisation. Des panneaux de signalisation seront placés à des endroits visibles le long du parcours, dont un exemplaire sera affiché dans le hall d'inscription. Les organisateurs ne peuvent en aucun cas être tenus responsables des cyclistes et/ou suiveurs qui s'égarent.

ART.16. Barème de points UCI. 1) 40p 2) 30p 3) 25p 4) 20p 5) 15p 6) 10p 7) 5p 8) 3p 9) 3p 10) 3p

ART. 17. Vestiaires sportcomplex De Bres, Monseigneur Senciestraat 13, 1500 Halle // Tel : 02/365 98 40



# COMPETITION RULES GRAND PRIX STAD HALLE ME 1.2

## 31 AUGUST 2025

ART.1. Organisation. "De Grote Prijs Stad Halle - IXINA CLASSIC - " is organised by Halle Cycling vzw (Jozef Debusscherstraat 49 , 1500 Halle - Belgium). This international race will be ridden on Sunday 31 august 2025 according to the regulations of the UCI and Belgian Cycling (KBWB).

ART.2. Type of race & participation. The Grand Prix Stad Halle is a competition ME1.2 UCI for elites and promises from following teams: - Belgian UCI ProTeams - Foreign UCI ProTeams (max. 2) - UCI continental teams - UCI professional cyclo cross teams - National teams - Regional and club teams - The minimum number of riders per team is set at 5, maximum 7.

ART.3. Permanence. The permanence at the start will be at the Colruyt Group premises, Edingensesteenweg 196 - 1500 Halle - +32 474 78 98 28, on Sunday 31 August 2025 from 7.30AM. end 6.00PM. The confirmation of the participants arriving at the start and the collection of the bib numbers by the team manager will take place at the permanence between 8.30AM and 10.00PM. The meeting with the team leaders, in the presence of the College of Commissioners, will take place at 10.15AM. in accordance with Art. 1.2.2. The meeting with the team managers, in the presence of the College of Commissioners, takes place in the same building at 10.15AM., in accordance with Art. 1.2.087 of the UCI regulations. The permanence at the finish will take place on Sunday 31 August 2025, in the Colruyt Group buildings, Edingensesteenweg 196 - 1500 Halle

ART.4. Radio Tour. Competition information will be broadcast on channel 1 of "Radio Tour" on 164.63125 MHz.

ART.5. Neutral Technical Assistance. Neutral technical assistance is ensured by MERIDA. This service is provided by 2 neutral vehicles and 1 moto

ART.6. Safety. Participants and authorised followers are obliged to immediately follow all instructions of the course management, officials and federal police.

ART.7. Start procedure. All riders are asked to participate in the team presentation on the podium at the unofficial start. The presentation will take place at the Colruyt Group car park between 11.00AM and 12.15PM Double bib numbers and team outfit are compulsory. Every rider is obliged to line up at the unofficial start line and take the start from there.

ART.8. Time limit. Any rider who arrives outside the time limit of 8% behind the winner's time will not be classified. The time limit can be increased by the Board of Commissioners, in consultation with the organiser, in case of exceptional circumstances.

ART.9. Rankings - Bonifications. The following ranking will be drawn up: the individual final ranking according to the order of crossing the finish line at the end of the last local lap. The ranking determines the allocation of prizes. There are no other rankings or bonuses.

ART.10. Classification prizes. The prize package totals €6,050 and is determined as follows: 1) €2.425 2) €1.210 3) € 610 4) € 305 5) € 240 6) € 180 7) € 180 8) € 120 9) € 120 10) € 60 11) € 60 12) € 60 13) € 60 14) € 60 15) € 60 16) € 60 17) € 60 18) € 60 19) € 60 20) € 60

ART 11. : Additional prizes donated by IXINA: 1st: voucher €5.000.00 / 2nd voucher €3.000.00 / 3rd voucher €2.000.00

GPM :BRUINEPUT : 1ste : 500€, 2de : 300€, 3de : 200 €  
Passage : 2,3,4,5,6 /// Punten **1st** : 5p, **2d** : 3p, **3d** : 1p To qualify , the rider must complete the entire race

ART.12. Medical control - Anti-doping control. The UCI anti-doping regulations apply in full to this race. In addition, the Belgian anti-doping legislation applies, in accordance with the legal regulations of Belgium and according to the anti-doping legislation of the Flemish Region. The antidoping control will take place at Colruyt Group, Edingensesteenweg 196 , 1500 Halle

ART.13. Protocol. According to Article 1.2.112 of the UCI regulations, the following riders must present themselves for the protocol: the first three classified riders of the race. They will present themselves in a maximum time limit of 10 minutes after their arrival, as well as winner of the GPM

ART.14. Penalties. The UCI penalty scale is the only one applicable.

ART.15. Signposts. Signposts will be placed at visible places along the course, a specimen of which will be displayed in the registration hall. The organisers cannot be held liable in any way for cyclists and/or followers who lose their way.

ART.16. UCI points scale. 1) 40p 2) 30p 3) 25p 4) 20p 5) 15p 6) 10p 7) 5p 8) 3p 9) 3p 10) 3p

ART. 17 . Dressing Rooms : sportcomplex De Bres , Monseigneur Senciestraat 13 , 1500 Halle // Tel : 02/365 98 40



Kleedkamers - Vestiaires - Dressing  
Rooms

Monseigneur Senciestraat 13 , 1500 Halle  
Tel. : 02 365 98 40



